



arkè[®]

by **ALBINI & FONTANOT**[®]

English

ASSEMBLY INSTRUCTIONS

KLAN



∅ 8x300 12x120 14x150 mm

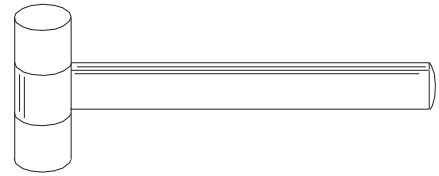

∅ 2.5 3.5 4.5 mm

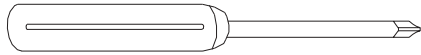

PH 2

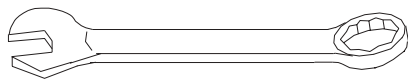
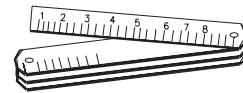
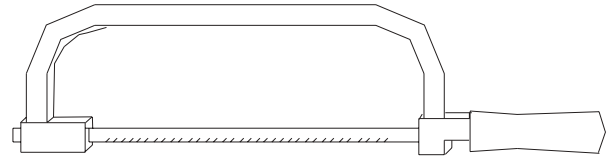

13 17 30 mm

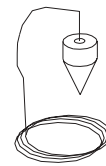

2.5 3 4 5 12 mm

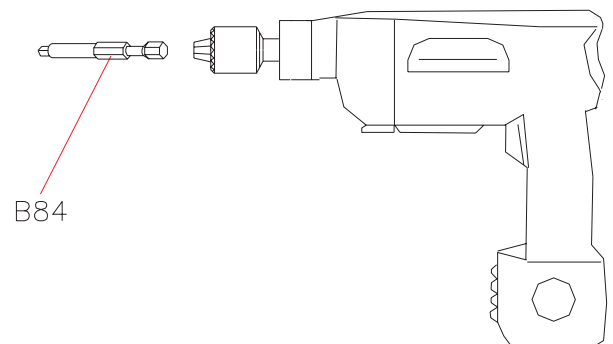
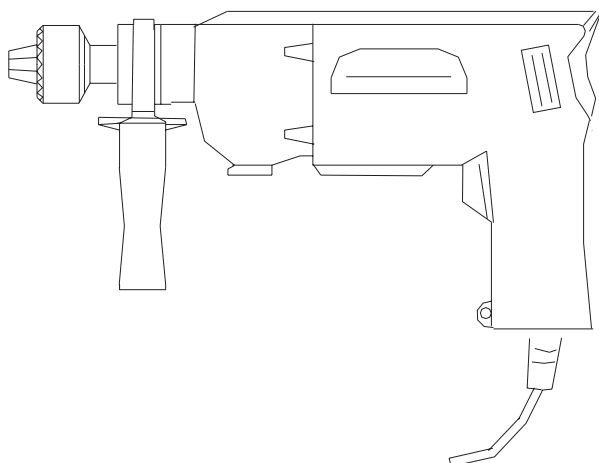
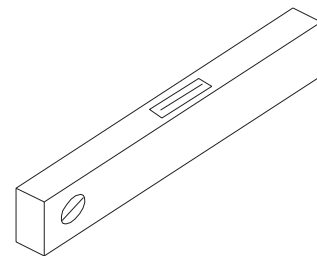

B84

Before starting the assembly process, unpack all components of the staircase. Lay them out on a large surface and check the quantity of all the pieces, by consulting the table TAB.1 (A = Code, B = Quantity). Inside the staircase box you will also find a video tape which we suggest watching before proceeding to assemble. For the USA only: call the customer support line at 1-888 STAIRKT, should you have any case of need.

Preliminary Assembly

1. Assemble the parts C24, C25 and B20 to the treads (L03) (fig. 2).
2. Carefully measure the floor-to-floor height and determine the required number of spacers (D08) (TAB.2) and prepare them onto their proper spacer (D15) (TAB2)
3. Assemble the parts B65, B66, B67 onto the baluster (C03), by using the part B68 (fig. 3).
4. Assemble the base G03, B17 and B46 (fig. 1).

Assembly

5. Determine and mark on the floor the centre of the opening, then position the base (G03+B17+B46) (fig. 4).
6. Drill with drill bit Ø 14 and fix the base (G03+B17+B46) into the floor by means of the parts B13 (fig. 1).
7. Screw the pole (G02) into the base (G03+B17+B46) (fig. 1).
8. Insert the base plate cover (D12) into the pole (G02) (fig. 5).
9. Insert the spacers (D08), then the shorter spacer (D14), the spacers (D08), the first tread (L03), the spacers (D08), the spacer (D15), the spacers (D08) and another tread (L03) and so on. Add alternatively the treads alternately one to the right and one to the left, so as to distribute the weight in a balanced way (fig. 5).
10. When you reach the end of the pole (G02), screw the part B47 on it, then add the second pole (G02) and continue with the stair assembly (fig. 5)
11. When you reach the end of the pole (G02), screw on it the part B46 and the part G01. (Screw the part G01, until its upper end sticks out approximately 15cm (6") from the stair height (fig. 6). Continue adding the treads, by using the part D01 inserted into the tread (L03).
12. Finally add the stair landing (E02). After having chosen the stair rotation (fig. 7), position the landing (E02) with the small hole (which is needed for the baluster passage (C03)) on the arrival side of the treads (L03) (fig. 8) Cut the landing (E02), if necessary, in relation to the floor opening.
13. Insert the parts B05, B04 and screw the part B03 sufficiently (fig. 1) but keeping in mind that the treads still have to be rotated (fig. 1).

Fitting of the Landing

14. Approach the part F12 to the floor. Determine the position, maintaining a distance of about 15cm (6") from the external side of the landing (E02), pierce with drill bit Ø 14 and fix securely by using the part B13 (fig. 1).
15. Fix the parts F12 to the landing (E02), by using the parts B11 (pierce the landing (E02) with the drill bit Ø 5).
16. Position the parts B95.

Assembly of the Railing

17. Spread-out the treads (L03) fan-like. It is now possible to use the stair.
18. Starting from the landing (E02), insert the longer railing balusters (C03), that build the connection between the treads (L03). Keep the balusters (C03) with the part B65 and the pierced part to the top (fig. 8). Tighten only the part B02 of the lower tread (fig. 2).
19. Check very carefully the vertical position of the inserted balusters C03. This control is very important for insuring the best results.
20. Tighten securely the part B03 (fig. 8).
21. Tighten securely the part B02 of the upper tread (fig. 2).
22. Check once more the vertical position of the railing balusters (C03) and, if necessary, correct it, by repeating the previous operations.
23. Position the first baluster (C03) together with the reinforcing part (F07). Cut one long baluster (C03) to obtain the same size as all others you assembled previously.
24. Fix into the floor in relation to the first baluster (C03), the part F01, by piercing with the drill bit Ø 8. Use the parts B11, B12, B83 and B02 (fig. 1).
25. Find the handrail piece marked with letter "M" (A06) and the one with letter "R" (A04) which will be used for the railing of the landing (E02) (fig. 9).
26. Start to model the handrail pieces (A06) marked with "M", trying to give it a shape that corresponds the nearest possible to the curve of the staircase (fig. 1).

27. Beginning from the baluster (C03) on the landing (E02), start to fasten the handrail (A06), that you have already slightly bent in the previous operation. Use the parts B16 together with the screw driver and the item B84.
28. Connect all other handrail pieces (A06), by screwing, glueing and shaping them. Use the parts B33 and the glue (X01).
29. When you reach the first baluster (C03) at the bottom of the stair, cut the excess piece of the handrail with a hacksaw.
30. Complete the handrail (A06) by assembling the part A07. Use the parts B16 and the glue (X01) (fig. 1).
31. Insert all remaining railing balusters into the treads (L03), tighten the part B02 and fix to the handrail (A06), paying careful attention to the vertical position. (for the stairs with a diameter larger than 140cm(4' 7 1/8"), we suggest that you first assemble the shorter balusters) (fig. 10).
32. Check again the regular shape of the handrail (A06) and, if necessary, correct it with a rubber hammer.
33. Complete the railing assembly by fitting the parts B82 into the lower part of the balusters (C03) and the parts C19 into the lateral part of the treads (fig. 1).

Assembly of the Balustrade

34. Screw the baluster (C04) into the part G01 that sticks out from the landing (E02) (fig. 8).
35. Set the parts F01, by using the parts B11, B83, B02 onto the landing (E02). Pierce with the drill bit Ø 5 the landing (E02), maintaining a similar distance between the holes as the one between the already assembled railing balusters (C03).
36. Set the shorter balusters (C03) and tighten the part B02 (fig. 1)
37. Fix the part A05 into the baluster (C04), by using the part B02 (fig. 1).
38. Fix the handrail (A04) marked with the letter "R", using the parts B16 (fig. 1).
39. In case there were walls around the stair well and on their position, it could be necessary to position one or two more balusters (C03) (fig. 10).
40. In that case it is necessary to consider either the distance between all other balusters, or otherwise the distance from the wall. For the fixing it is suggested to pierce the landing (E02) with a drill bit Ø 5 and to use the fixing parts F01, B11, B83, B02. Whereas for the fixing into the floor it is suggested to pierce the floor with a drill bit Ø 12 and to use the parts F01, B02, B87 (fig. 11).

Final Assembly

41. In order to re-inforce the staircase at the intermediate points, you must fix into the wall the parts F09 and connect them to the balusters (C03) by means of the parts F08. Pierce the wall with a drill bit Ø 8 and use the parts B85, B86, B11, B12 (fig. 12).

We would be grateful, if you could send us any possible suggestion by visiting our Internet Site:
www.arke.ws

TAB. 1

A	B		
	<u>Ø 120</u> 3' 11 1/4"	<u>Ø 140</u> 4' 7 1/8"	<u>Ø 160</u> 5' 3"
A04	1	1	1
A05	2	2	2
A06	5	5	5
A07	3	3	3
B02	13	15	15
B03	1	1	1
B04	1	1	1
B05	1	1	1
B11	21	23	26
B12	7	7	10
B13	6	6	6
B16	73	101	101
B17	1	1	1
B20	40	52	52
B33	6	6	6
B46	2	2	2
B47	1	1	1
B65	33	47	47
B66	33	47	47
B67	33	47	47
B68	1	1	1
B82	24	36	36
B83	9	11	11
B84	1	1	1
B85	2	2	3
B86	2	2	3
B95	3	3	3
C03	33	47	47
C04	1	1	1
C19	40	52	52
C23	2	2	2
C24	77	101	101
C25	40	52	52
D01	4	6	6
D08	119	119	119
D12	1	1	1
D14	1	1	1
D15	12	12	12
E02	1	1	1
F01	9	11	11
F07	1	1	1
F08	2	2	3
F09	2	2	3
F12	3	3	3
G01	1	1	1
G02	2	2	2
G03	1	1	1
L03	12	12	12
X01	1	1	1

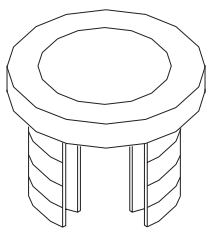

C24

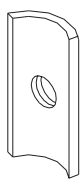

C25



B20

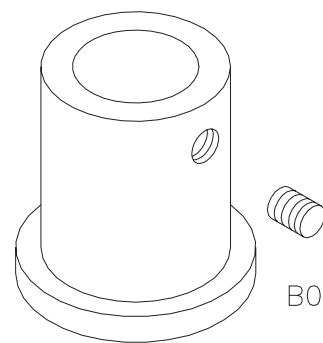

B02

F01



B84

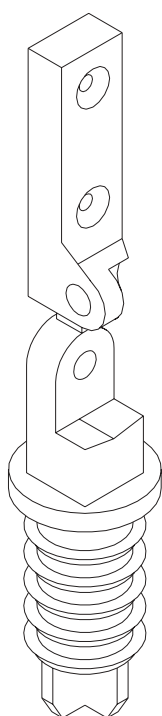

B65

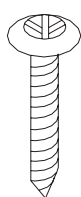

B16



C19

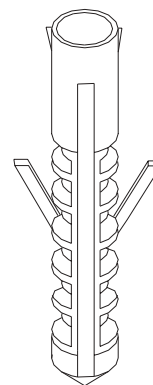

B12

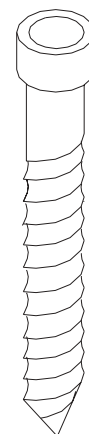

B11

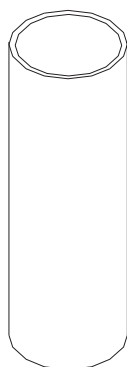

B68



B82

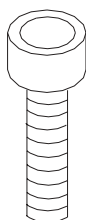

B85



B86



B83



B66

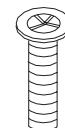

B67

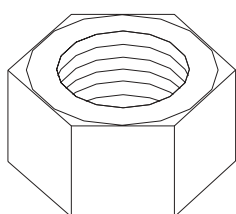

B03

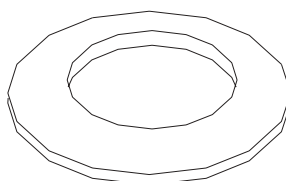

B04

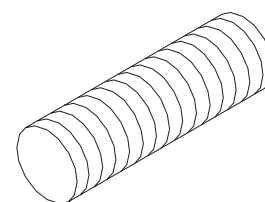

B33

TAB.2

To determine the necessary number of spacers (D08), you must look-up the table TAB.2 (H = Height, A = Rises, X = quantity of spacers (D08) to position onto the spacer (D15), Y = quantity of the spacers (D08) to position onto the spacer (D14).

Example: given a floor-to-floor height of 298cm (9' 9 3/8") and a staircase with 13 treads, you must proceed as follows;

1. At height (298cm (9' 9 3/8")) in the row H) look-up the number of necessary spacers (X=6, Y=12, in the row A/13)
2. Distribute the spacers (D08), as follows 6 spacers (D08) onto every spacer (D15) positioning three spacers on the top and three spacers on the bottom, twelve spacers (D08) onto the only spacer (D14), the shortest one, positioning three on the top and nine on the bottom

TAB. 2

H	10		A		11		H	12		A		13		H	14		A		15		H	16		A		17	
	X	Y	X	Y	X	Y		KIT	X	Y	X	Y	X		Y	X	Y	X	Y	X		Y	X	Y	X	Y	X
210	0	2					253	0	5					296	0	7					338	0	5				
211	0	6					254	0	8					297	0	10					339	0	9				
212	0	9					255	0	12					298	1	1					340	0	12				
213	1	3					256	1	4					299	1	4					341	11	1				
214	1	7					257	1	7					300	1	7					342	1	4				
215	2	1					258	1	11					301	1	11					343	1	7				
216	2	4					259	2	2					302	2	1					344	1	10				
217	2	8					260	2	6					303	2	4					345	1	13				
218	3	2					261	2	10					304	2	8					346	2	2				
219	3	5					262	3	2					305	2	11					347	2	5				
220	3	9					263	3	5					306	3	1					348	2	9				
221	4	3					264	3	9					307	3	5					349	2	12				
222	4	6					265	3	12					308	3	8					350	2	15				
223	5	1					266	4	4					309	3	11					351	3	4				
224	5	4					267	4	8					310	4	2					352	3	7				
225	5	7					268	4	11					311	4	5					353	3	10				
226	6	2					269	5	3					312	4	8					354	3	13				
227	6	5					270	5	7					313	4	11					355	4	2				
228	6	8					271	5	10					314	5	2					356	4	5				
229	7	3					272	6	2					315	5	5					357	4	9				
230	7	6					273	6	6					316	5	8					358	4	12				
231	7	9					274	6	9			0	4	317	5	12			0	6	359	4	15			0	4
232	8	4		0	6	275	6	12			0	8	318	6	2			0	9	360	5	4			0	7	
233	8	7		0	9	276	7	5			0	11	319	6	6			0	12	361	5	7			0	10	
234	8	10		0	12	277	7	8			1	2	320	6	9			1	2	362	5	10			0	14	
235	8	14		1	6	278	7	11			1	6	321	6	12			1	5	363	5	12			1	1	
236				1	9	279	8	4			1	9	322	7	3			1	9	364	6	2			1	4	
237				1	12	280	8	7			1	12	323	7	6			1	12	365	6	5			1	8	
238				2	6	281	8	10			2	4	324	7	9			2	1	366	6	9			1	11	
239				2	9	282	8	13			2	7	325	7	12			2	5	367	6	12			1	14	
240				2	12	283					2	10	326	8	3			2	8	368	6	14			2	2	
241				3	6	284					3	2	327	8	6			2	11	369	7	4			2	5	
242				3	9	285					3	5	328	8	9			3	1	370	7	7			2	8	
243				3	12	286					3	8	329	8	12			3	4	371	7	9			2	12	
244				4	6	287					3	12	330	8	15			3	7	372	7	10			2	15	
245				4	9	288					4	3	331					3	11	373	7	12			3	2	
246				4	12	289					4	6	332					3	14	374	8	5			3	6	
247				5	6	290					4	10	333					4	3	375	8	9			3	9	
248				5	9	291					5	1	334					4	7	376	8	12			3	12	
249				5	12	292					5	4	335					4	10	377	8	15			3	16	
250				6	6	293					5	8	336					4	13	378					4	3	
251				6	9	294					5	11	337					5	3	379					4	6	
252				6	12	295					6	2	338					5	6	380					4	10	
253				7	6	296					6	6	339					5	9	381					4	13	
254				7	9	297					6	9	340					5	12	382					5	0	
255				7	12	298					6	12	341					6	2	383					5	4	
256				8	6	299					7	4	342					6	5	384					5	7	
257				8	9	300					7	7	343					6	9	385					5	10	
258				8	12	301					7	10	344					6	12	386					5	14	
259						302					8	2	345					7	1	387					6	1	
260						303					8	5	346					7	5	388					6	4	
261						304					8	8	347					7	8	389					6	8	
262						305					8	12	348					7	11	390					6	11	
263						306					8	14	349					8	1	391					6	14	
264						307							350					8	4	392					7	2	
265						308							351					8	7	393					7	5	
266						309							352					8	11	394					7	8	
267						310							353					8	13	395					7	12	
268						311							354							396					7	15	
269						312							355							397					8	2	
270						313							356							398					8	6	
271						314							357							399					8	9	
272						315							358							400					8	12	
273						316							359							401					8	16	

TAB. 2

H	10		A		11		H	12		A		13		H	14		A		15		H	16		A		17	
	X	Y	X	Y	X	Y		KIT	X	Y	X	Y	X		Y	X	Y	X	Y	X		Y	X	Y	X	Y	X
6'10 5/8"	0	2					8' 3 5/8"	0	5					9' 8 1/2"	0	7					11' 1 1/8"	0	5				
6'11 1/8"	0	6					8' 4 "	0	8					9' 8 7/8"	0	10					11' 1 1/2"	0	9				
6'11 1/2"	0	9					8' 4 3/8"	0	12					9' 9 3/8"	1	1					11' 1 7/8"	0	12				
6'11 7/8"	1	3					8' 4 3/4"	1	4					9' 9 3/4"	1	4					11' 2 1/4"	11	1				
7' 1/4"	1	7					8' 5 1/8"	1	7					9' 10 1/8"	1	7					11' 2 5/8"	1	4				
7' 5/8"	2	1					8' 5 5/8"	1	11					9' 10 1/2"	1	11					11' 3 "	1	7				
7' 1 "	2	4					8' 6 "	2	2					9' 10 7/8"	2	1					11' 3 3/8"	1	10				
7' 1 3/8"	2	8					8' 6 3/8"	2	6					9' 11 1/4"	2	4					11' 3 7/8"	1	13				
7' 1 7/8"	3	2					8' 6 3/4"	2	10					9' 11 3/4"	2	8					11' 4 1/4"	2	2				
7' 2 1/4"	3	5					8' 7 1/8"	3	2					10' 1/8"	2	11					11' 4 5/8"	2	5				
7' 2 5/8"	3	9					8' 7 1/2"	3	5					10' 1/2"	3	1					11' 5 "	2	9				
7' 3 "	4	3					8' 8 "	3	9					10' 7/8"	3	5					11' 5 3/8"	2	12				
7' 3 3/8"	4	6					8' 8 3/8"	3	12					10' 1 1/4"	3	8					11' 5 3/4"	2	15				
7' 3 3/4"	5	1					8' 8 3/4"	4	4					10' 1 5/8"	3	11					11' 6 1/4"	3	4				
7' 4 1/4"	5	4					8' 9 1/8"	4	8					10' 2 "	4	2					11' 6 5/8"	3	7				
7' 4 5/8"	5	7					8' 9 1/2"	4	11					10' 2 1/2"	4	5					11' 7 "	3	10				
7' 5 "	6	2					8' 9 7/8"	5	3					10' 2 7/8"	4	8					11' 7 3/8"	3	13				
7' 5 3/8"	6	5					8' 10 1/4"	5	7					10' 3 1/4"	4	11					11' 7 3/4"	4	2				
7' 5 3/4"	6	8					8' 10 3/4"	5	10					10' 3 5/8"	5	2					11' 8 1/8"	4	5				
7' 6 1/8"	7	3					8' 11 1/8"	6	2					10' 4 "	5	5					11' 8 1/2"	4	9				
7' 6 1/2"	7	6					8' 11 1/2"	6	6					10' 4 3/8"	5	8					11' 9 "	4	12				
7' 7 "	7	9					8' 11 7/8"	6	9		0	4	10' 4 3/4"	5	12			0	6		11' 9 3/8"	4	15		0	4	
7' 7 3/8"	8	4	0	6		9' 1/4"	6	12		0	8	10' 5 1/4"	6	2			0	9		11' 9 3/4"	5	4		0	7		
7' 7 3/4"	8	7	0	9		9' 5/8"	7	5		0	11	10' 5 5/8"	6	6			0	12		11' 10 1/8"	5	7		0	10		
7' 8 1/8"	8	10	0	12		9' 1 "	7	8		1	2	10' 6 "	6	9			1	2		11' 10 1/2"	5	10		0	14		
7' 8 1/2"	8	14	1	6		9' 1 1/2"	7	11		1	6	10' 6 3/8"	6	12			1	5		11' 10 7/8"	5	12		1	1		
7' 8 7/8"			1	9		9' 1 7/8"	8	4		1	9	10' 6 3/4"	7	3			1	9		11' 11 1/4"	6	2		1	4		
7' 9 1/4"			1	12		9' 2 1/4"	8	7		1	12	10' 7 1/8"	7	6			1	12		11' 11 3/4"	6	5		1	8		
7' 9 3/4"			2	6		9' 2 5/8"	8	10		2	4	10' 7 1/2"	7	9			2	1		12' 1/8"	6	9		1	11		
7' 10 1/8"			2	9		9' 3 "	8	13		2	7	10' 8 "	7	12			2	5		12' 1/2"	6	12		1	14		
7' 10 1/2"			2	12		9' 3 3/8"				2	10	10' 8 3/8"	8	3			2	8		12' 7/8"	6	14		2	2		
7' 10 7/8"			3	6		9' 3 7/8"				3	2	10' 8 3/4"	8	6			2	11		12' 1 1/4"	7	4		2	5		
7' 11 1/4"			3	9		9' 4 1/4"				3	5	10' 9 1/8"	8	9			3	1		12' 1 5/8"	7	7		2	8		
7' 11 5/8"			3	12		9' 4 5/8"				3	8	10' 9 1/2"	8	12			3	4		12' 2 1/8"	7	9		2	12		
8' 1/8"			4	6		9' 5 "				3	12	10' 9 7/8"	8	15			3	7		12' 2 1/2"	7	10		2	15		
8' 1/2"			4	9		9' 5 3/8"				4	3	10' 10 3/8"					3	11		12' 2 7/8"	7	12		3	2		
8' 7/8"			4	12		9' 5 3/4"				4	6	10' 10 3/4"					3	14		12' 3 1/4"	8	5		3	6		
8' 1 1/4"			5	6		9' 6 1/8"				4	10	10' 11 1/8"					4	3		12' 3 5/8"	8	9		3	9		
8' 1 5/8"			5	9		9' 6 5/8"				5	1	10' 11 1/2"					4	7		12' 4 "	8	12		3	12		
8' 2 "			5	12		9' 7 "				5	4	10' 11 7/8"					4	10		12' 4 3/8"	8	15		3	16		
8' 2 3/8"			6	6		9' 7 3/8"				5	8	11' 1/4"					4	13		12' 4 7/8"				4	3		
8' 2 7/8"			6	9		9' 7 3/4"				5	11	11' 5/8"					5	3		12' 5 1/4"				4	6		
8' 3 1/4"			6	12		9' 8 1/8"				6	2	11' 1 1/8"					5	6		12' 5 5/8"				4	10		
8' 3 5/8"			7	6		9' 8 1/2"				6	6	11' 1 1/2"					5	9		12' 6 "				4	13		
8' 4 "			7	9		9' 8 7/8"				6	9	11' 1 7/8"					5	12		12' 6 3/8"				5	0		
8' 4 3/8"			7	12		9' 9 3/8"				6	12	11' 2 1/4"					6	2		12' 6 3/4"				5	4		
8' 4 3/4"			8	6		9' 9 3/4"				7	4	11' 2 5/8"					6	5		12' 7 1/8"				5	7		
8' 5 1/8"			8	9		9' 10 1/8"				7	7	11' 3 "					6	9		12' 7 5/8"				5	10		
8' 5 5/8"			8	12		9' 10 1/2"				7	10	11' 3 3/8"					6	12		12' 8 "				5	14		
8' 6 "						9' 10 7/8"				8	2	11' 3 7/8"					7	1		12' 8 3/8"				6	1		
8' 6 3/8"						9' 11 1/4"				8	5	11' 4 1/4"					7	5		12' 8 3/4"				6	4		
8' 6 3/4"						9' 11 3/4"				8	8	11' 4 5/8"					7	8		12' 9 1/8"				6	8		
8' 7 1/8"						10' 1/8"				8	12	11' 5 "					7	11		12' 9 1/2"				6	11		
8' 7 1/2"						10' 1/2"				8	14	11' 5 3/8"					8	1		12' 10 "				6	14		
8' 8 "						10' 7/8"						11' 5 3/4"					8	4		12' 10 3/8"				7	2		
8' 8 3/8"						10' 1 1/4"						11' 6 1/4"					8	7		12' 10 3/4"				7	5		
8' 8 3/4"						10' 1 5/8"						11' 6 5/8"					8	11		12' 11 1/8"				7	8		
8' 9 1/8"						10' 2 "						11' 7 "					8	13		12' 11 1/2"				7	12		
8' 9 1/2"						10' 2 1/2"						11' 7 3/8"								12' 11 7/8"				7	15		
8' 9 7/8"						10' 2 7/8"						11' 7 3/4"								13' 1/4"				8	2		
8' 10 1/4"						10' 3 1/4"						11' 8 1/8"								13' 3/4"				8	6		
8' 10 3/4"						10' 3 5/8"						11' 8 1/2"								13' 1 1/8"				8	9		
8' 11 1/8"						10' 4 "						11' 9 "								13' 1 1/2"				8	12		
8' 12 1/2"						10' 4 3/8"						11' 9 3/8"								13' 1 7/8"				8	16		

FIG. 2

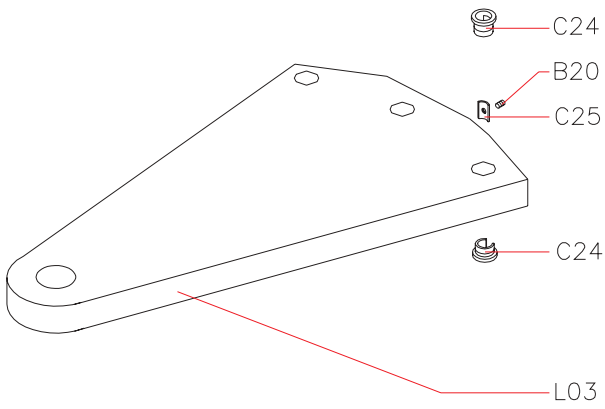

FIG. 3

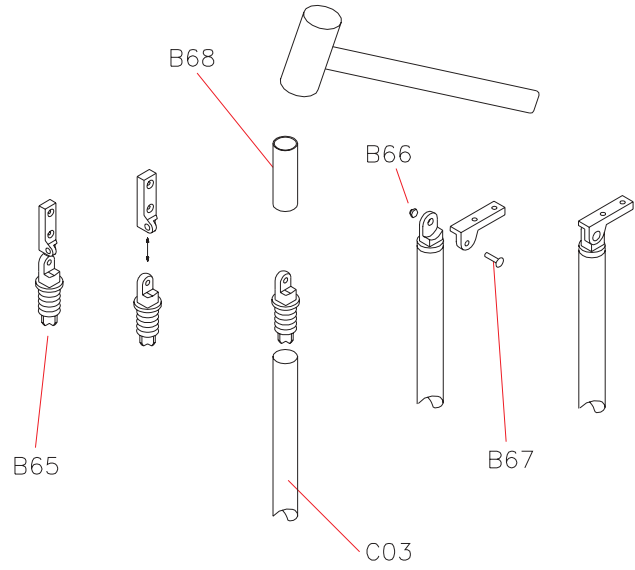

FIG. 4

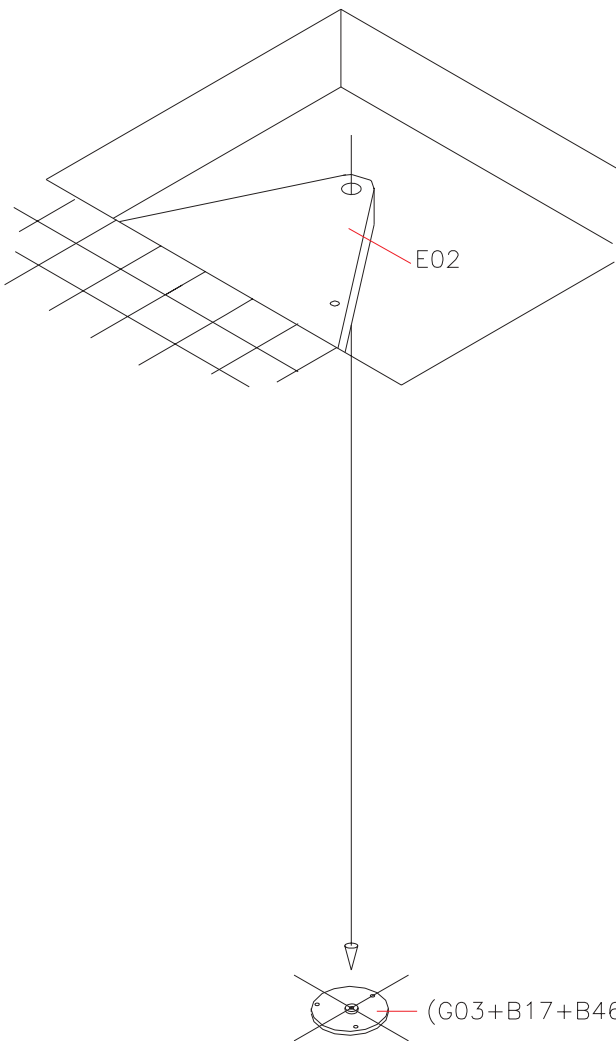

FIG. 5

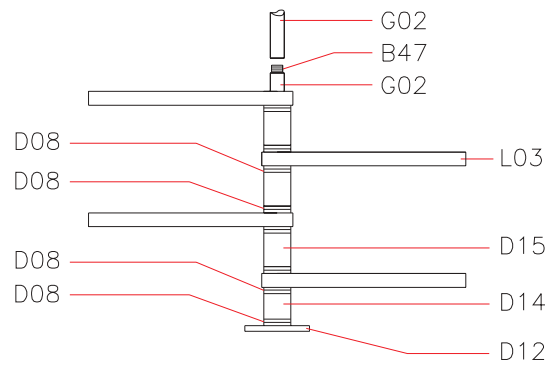

FIG. 6

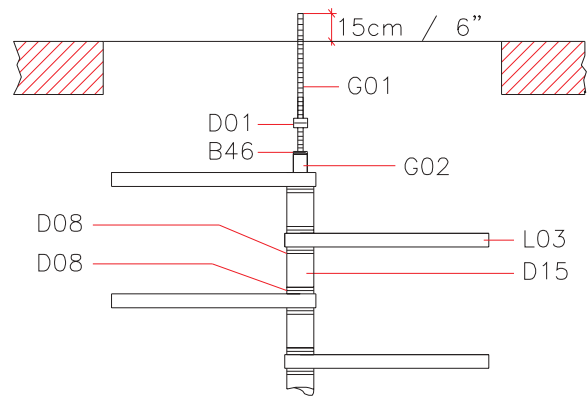
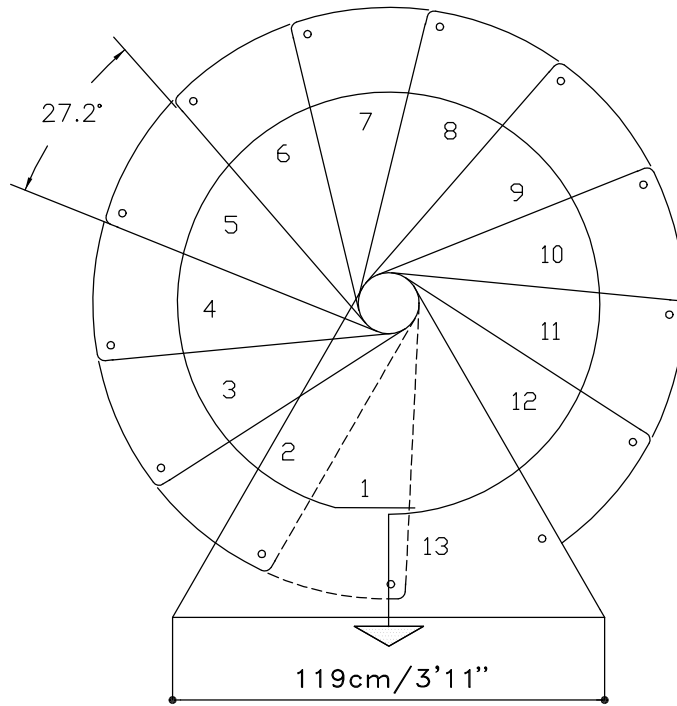
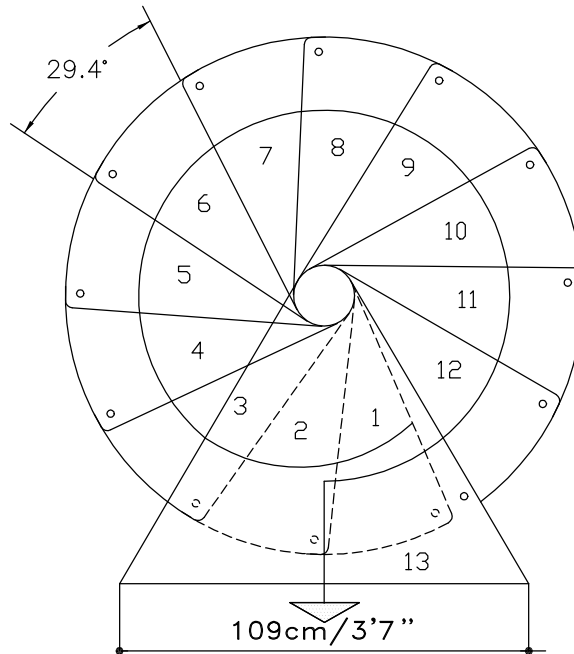
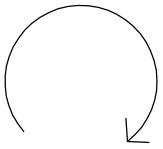

FIG. 7



Ø160 cm
Ø 5'3"



Ø140 cm
Ø 4'7 1/8"

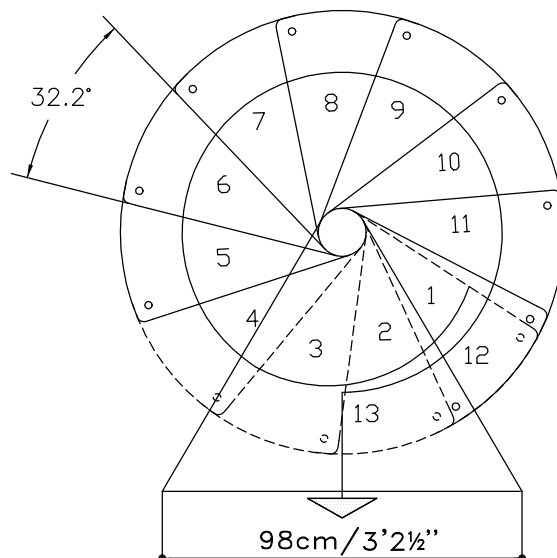
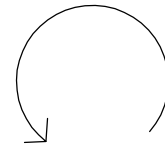

Ø120 cm
Ø 3'11 1/4"

FIG. 8

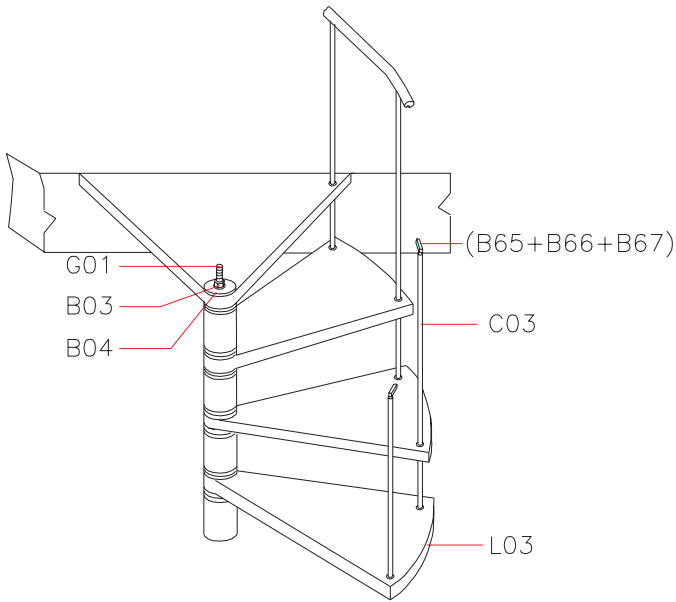

FIG. 9

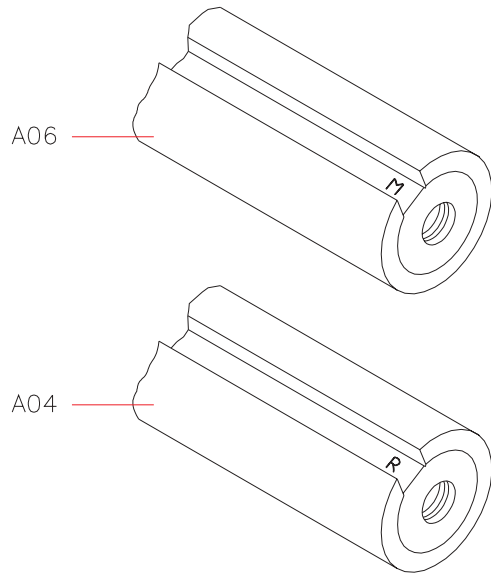

FIG. 10

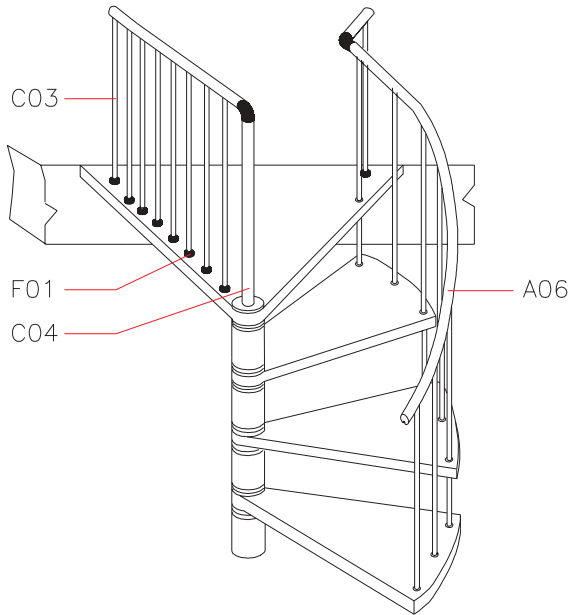

FIG. 11

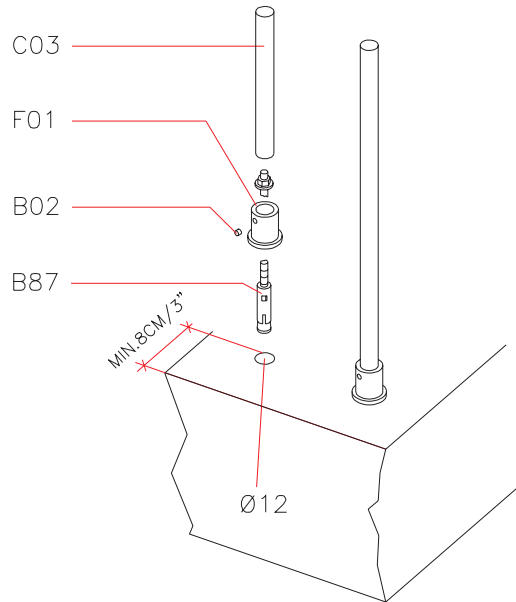
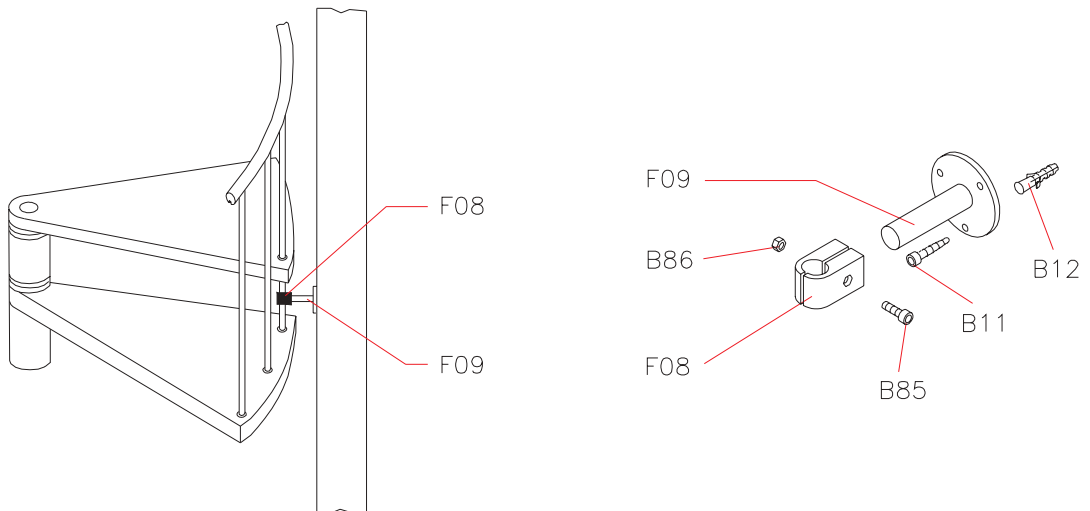
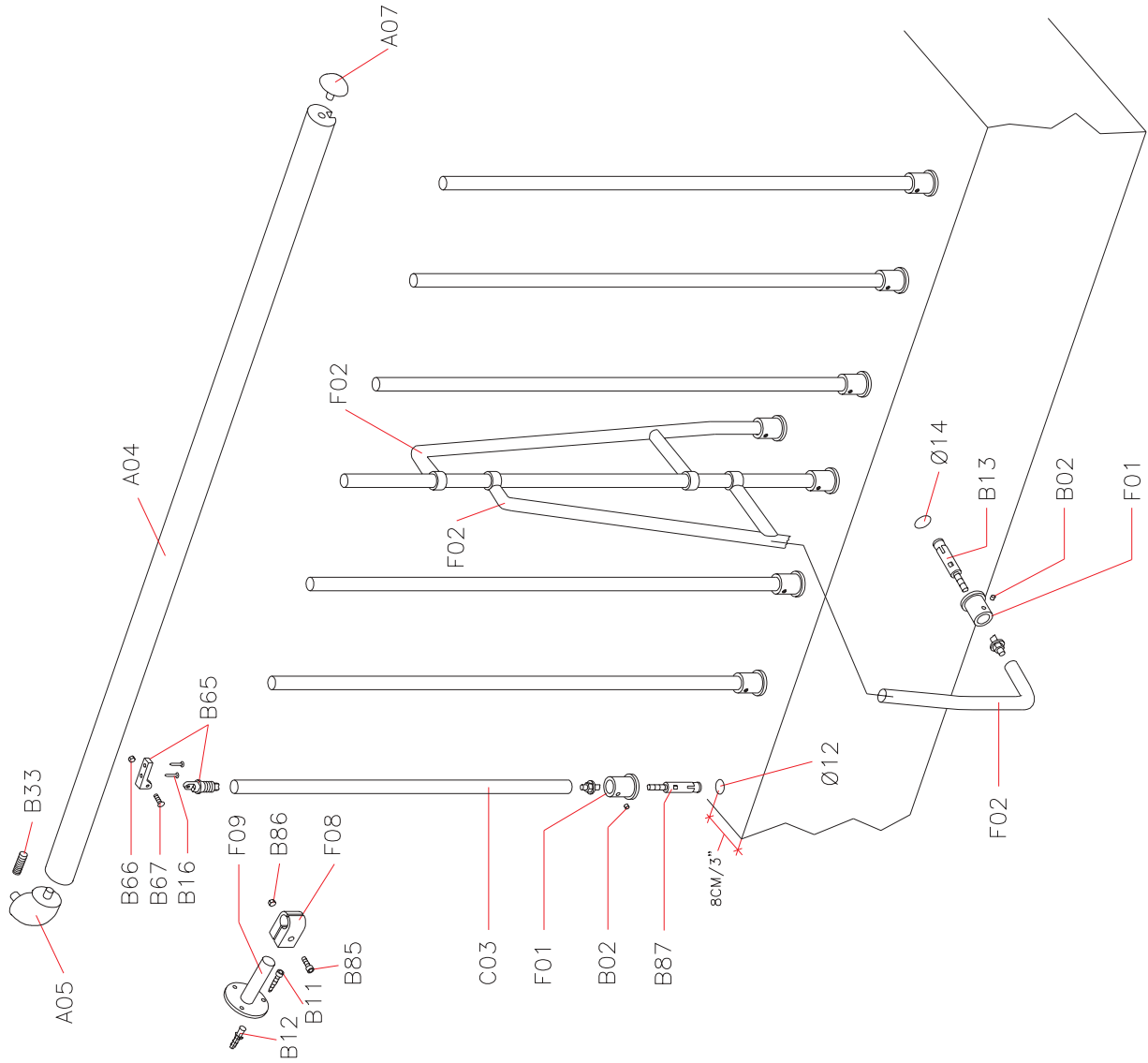

FIG. 12



BALUSTRADE

COD. 5054



N°=1	N°=10	N°=1
F02	C03	A04
N°=1	N°=2	N°=3
F09	A05	A07
N°=24	N°=11	N°=2
B16	F01	A07
N°=10	N°=13	N°=3
B67	B02	B87
B66	B65	B12
B65	B11	B11
B12	B11	B12
B11	B11	B11
B85	B85	B85
F08	F08	F08
B86	B86	B86
F09	F09	F09
B66	B66	B66
B67	B67	B67
B16	B16	B16
B65	B65	B65
B33	B33	B33
A05	A05	A05

